



北海道大学  
HOKKAIDO UNIVERSITY

13<sup>th</sup> IP Conference  
Innovation, Intangible Assets During and After the Global Pandemic

# Patentability and PHOSITA in the AI Era (with a focus on inventive step)

July 30, 2021

Ichiro Nakayama

Graduate School of Law, Hokkaido University (Japan)

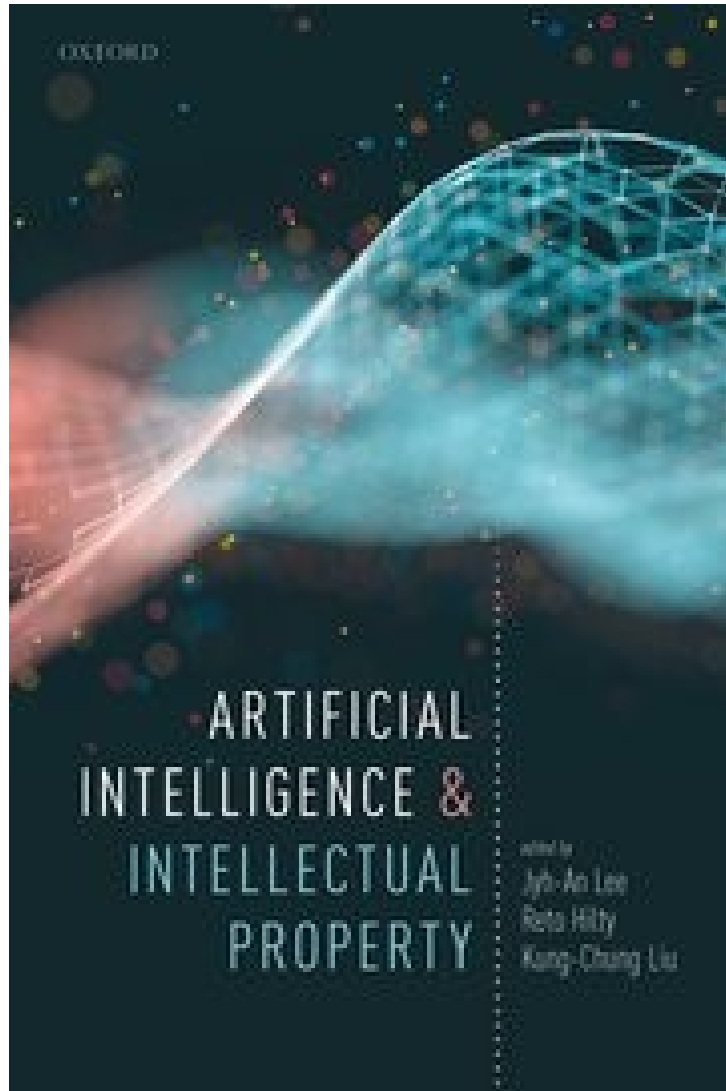

Jyh-An Lee, Reto Hilty, and Kung-Chung Liu eds.  
Artificial Intelligence and Intellectual Property  
Oxford University Press, 2021.

Chapter 5,  
Patentability and PHOSITA in the AI Era  
- A Japanese Perspective

<https://global.oup.com/academic/product/artificial-intelligence-and-intellectual-property-9780198870944?lang=en&cc=fr>

# Types of AI-related inventions

<b>(Type 1)</b> Inventions of AI technologies	Created by <b>humans</b> to improve AI technologies	<b>Not a few today</b>
<b>(Type 2)</b> AI- <b>assisted</b> inventions	Created by <b>humans</b> with the use of AI as a <b>tool</b>	<b>Not a few today</b>
<b>(Type 3)</b> AI- <b>generated</b> inventions	<b>Autonomously</b> generated by AI Instruction may be necessary e.g. “Generate something like ...”)	<b>Few today?</b> May increase in future?

# Applications of AI-related inventions in Japan

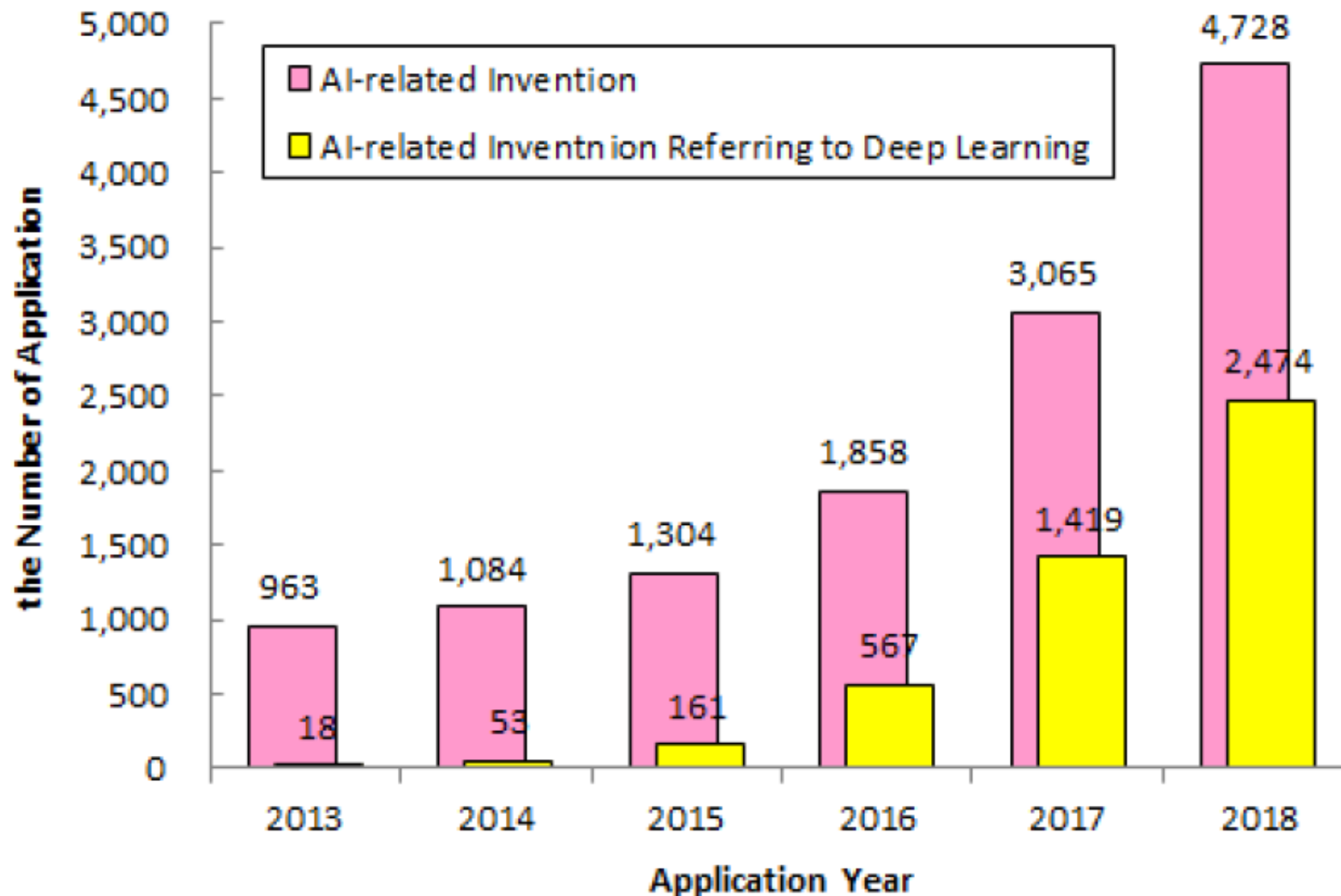

Source : Japanese Patent Office (JPO) [https://www.jpo.go.jp/e/system/patent/gaiyo/ai/ai\\_shutsugan\\_chosa.html](https://www.jpo.go.jp/e/system/patent/gaiyo/ai/ai_shutsugan_chosa.html)

# Categories of AI-related inventions in Japan

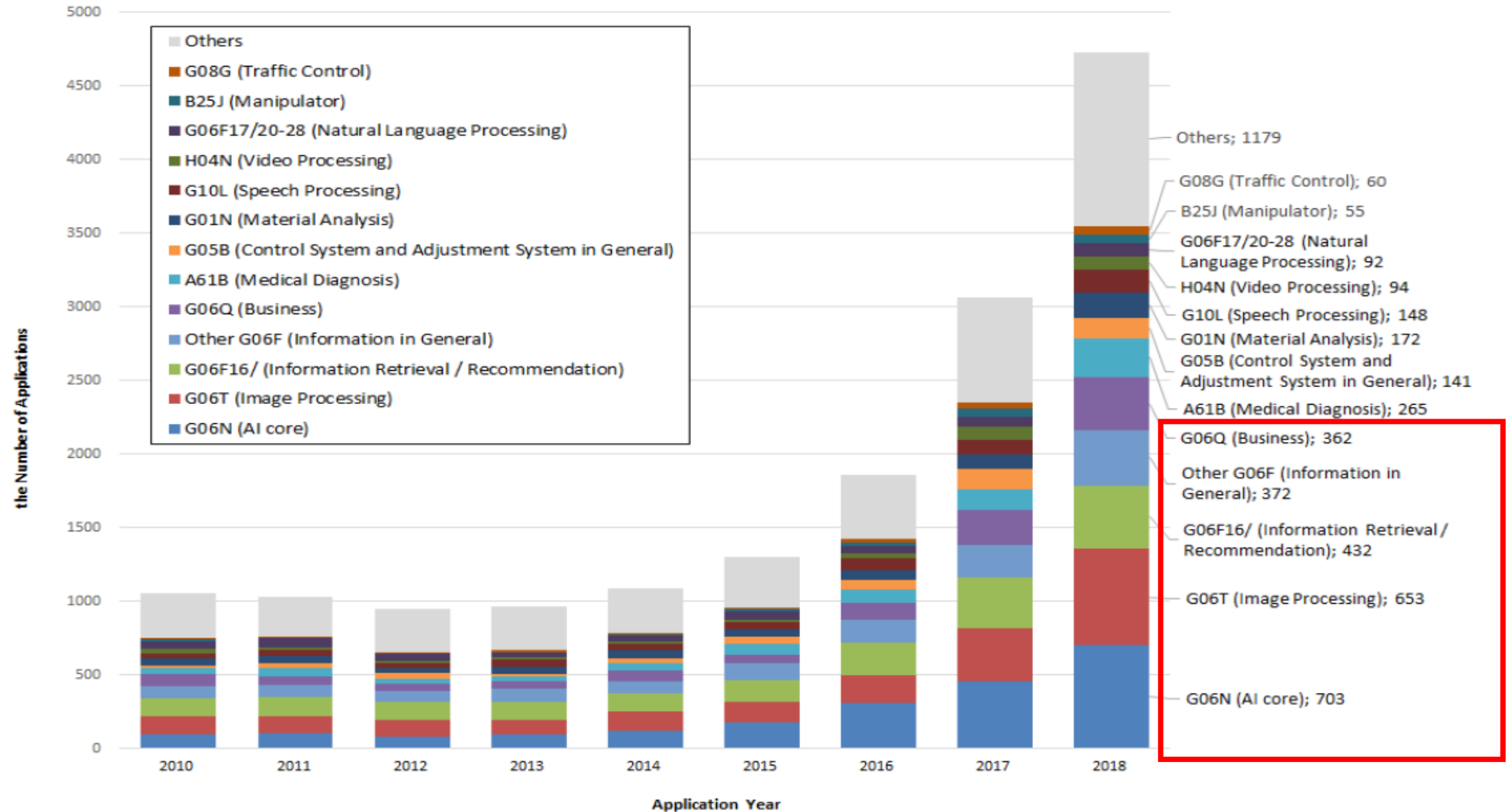

Source : Japanese Patent Office (JPO) [https://www.jpo.go.jp/e/system/patent/gaiyo/ai/ai\\_shutsugan\\_chosa.html](https://www.jpo.go.jp/e/system/patent/gaiyo/ai/ai_shutsugan_chosa.html)

# “Artificial Inventor Project”

---

- AI called “**DABUS**” allegedly invented autonomously
  - ✓ A food or beverage container
  - ✓ Devices and methods for attracting enhanced attention
- Applicants assert
  - ✓ **AI = inventor**
  - ✓ **AI’s owner = owner of the right** to obtain the patent

# “Food Container”

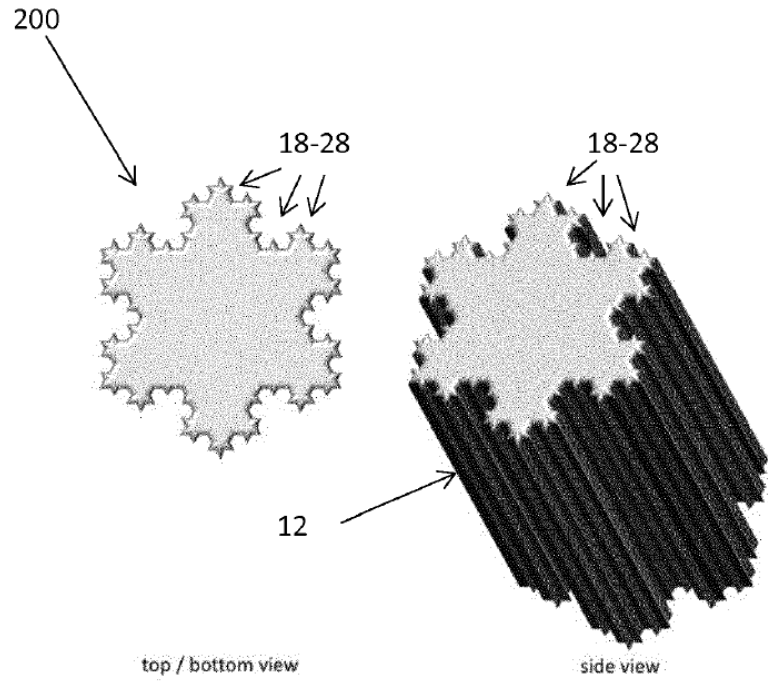

Fig. 6

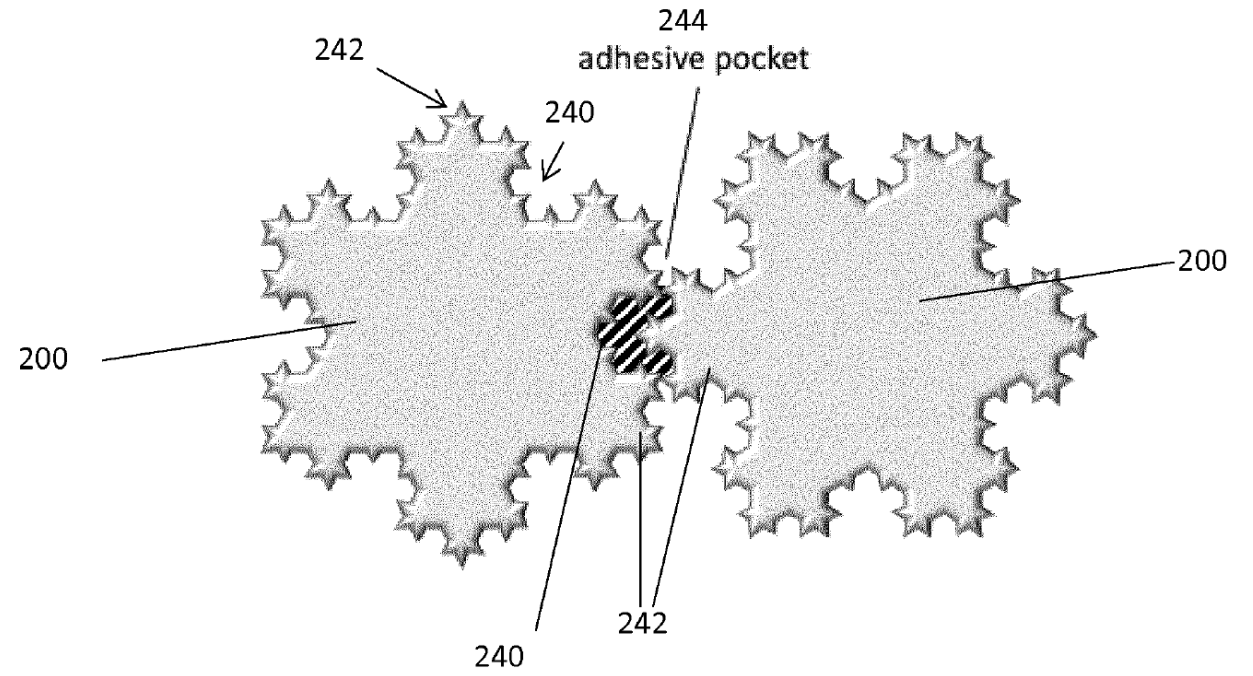

Fig. 7

EP 18275163

# “Devices and methods for attracting enhanced attention”

EP 18275174

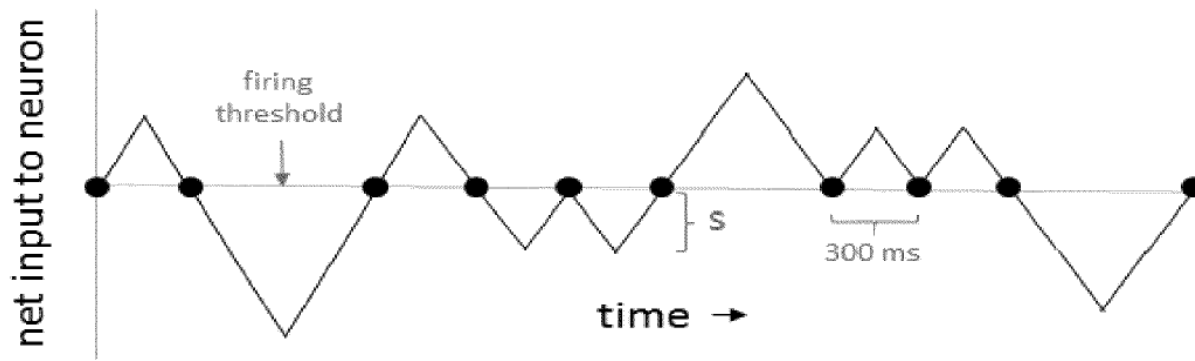

Figure 3

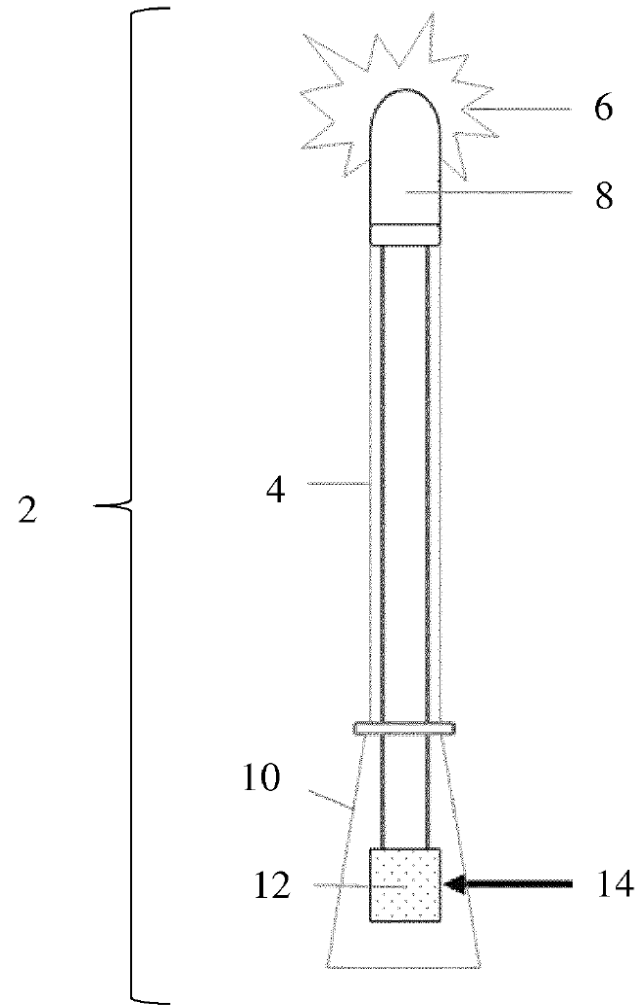

Figure 1

# “Artificial Inventor Project”

---

- 2 patent applications which claimed DABUS (AI) as inventors
- UKIPO, EPO and USTPTO rejected the applications
  - ✓ Inventor = natural person
  - ✓ AI has no legal rights and thus cannot assign any rights to AI owners
- Thaler v. The Comptroller-General of Patents, Designs And Trade Marks [2020] EWHC 2412 (Pat) (21 September 2020)

# Issues of AI-assisted inventions or inventions on AI technologies

---

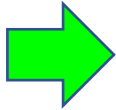
- ✓ Patent eligibilities
  - ✓ Description requirements
  - ✓ Inventive Step (Non-obviousness)
-  Japanese Patent Office (JPO)' s Examination Guidelines & Handbook addressed some of them (not all of them)

# Patent Eligibility

---

- Not a few AI-related inventions are **software**-related inventions
- If computer software is eligible for patent, so are AI-related inventions



Whether may software fall within the **definition of “invention”** or not?

Japanese Patent Act, Article 2 (1)

“**Invention**” in this act means the highly advanced creation of technical ideas **utilizing the laws of nature**.



Does software utilize the laws of nature?

# Does computer software utilize the laws of nature?

---

➤ Examination Handbook , Annex B Chapter1, 2.1.1.2(1)

(i) When ... "information processing by the software is concretely realized by using hardware resources," said software is a "creation" of a technical idea utilizing the laws of nature.



"a specific information processor or an operation method ... is constructed through cooperation of the software and the hardware resources"



Software-related inventions could be **patentable** (by careful claim drafting)  
So could **AI-related inventions** (type 1 and type 2)

# Example of Trained Model eligible for patent

➤ Examination Handbook , Annex B Chapter1, 3. Case 2-14

## Claim

A **trained model** for causing a computer to function to output quantified values of reputations of accommodations based on text data on reputations of accommodations, wherein;  
the model is comprised of a first **neural network** and a second **neural network** connected in a way that the said second neural network receives output from the said first neural network;

...

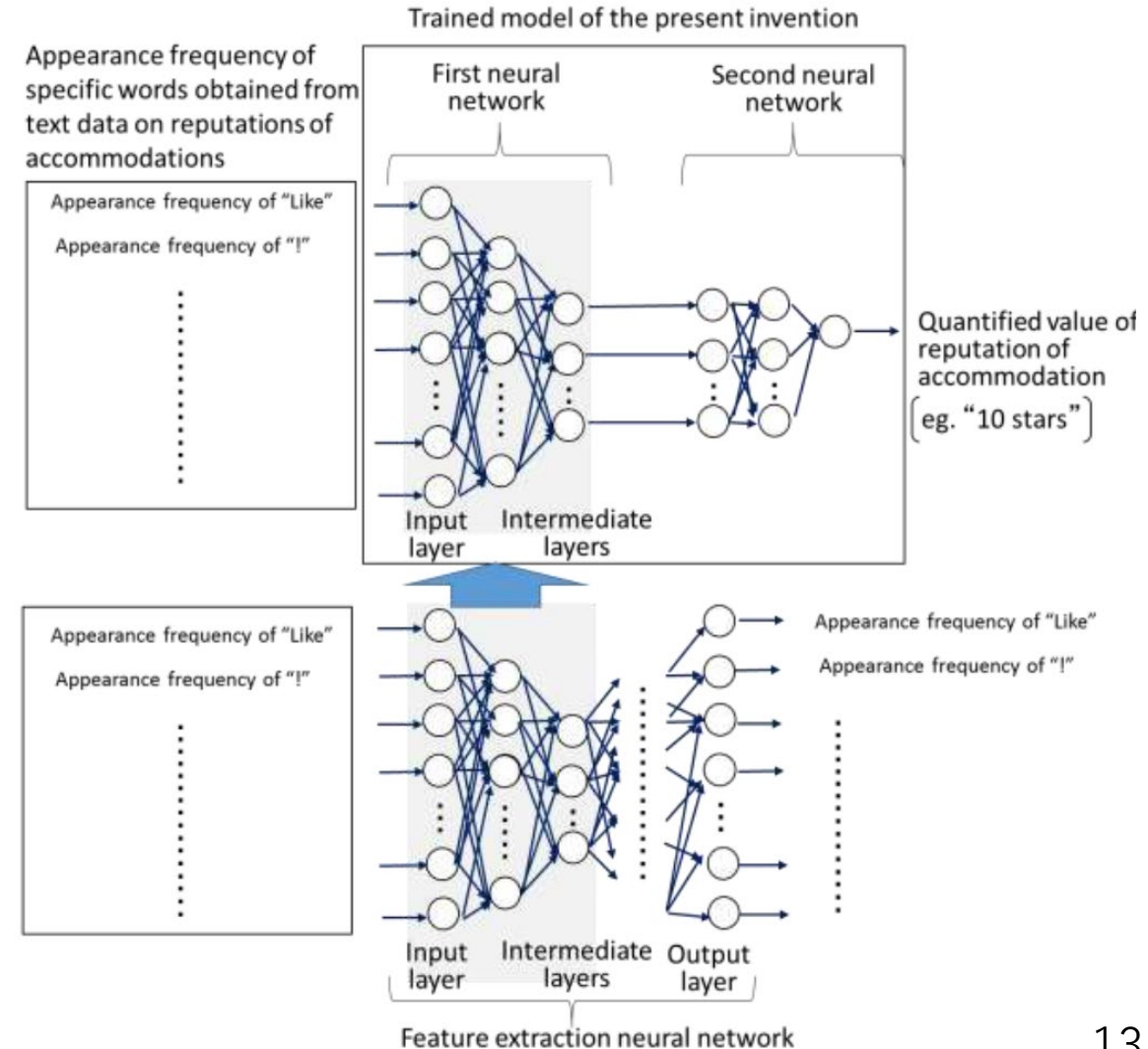

# Description Requirements

---

- No patent without disclosure
  - A patent is granted in exchange for disclosing an invention
- AI as a **black box** give no idea why AI produced the estimated results



**Person having ordinary skills in the arts (PHOSITA)**

may or may not understand

- ✓ How to work the invention
- ✓ How to solve a technical problem

# Description Requirements

---

## ➤ Enablement

Japanese Patent Act, Article 36 (4)

The statement of the **detailed explanation of the invention** ... shall be **clear and sufficient** as to **enable** any person ordinarily skilled in the art to which the invention pertains to work the invention; ...

## ➤ Support requirement

Japanese Patent Act, Article 36 (6)

The statement of the scope of **claims** ...shall comply with each of the following items:  
(i) the invention for which a patent is sought **is stated in the detailed explanation of the invention**; ...

# Description Requirement: Case Example 46

SUGAR CONTENT ESTIMATION SYSTEM



## Claim 1: Violation of the enablement requirement

A certain correlation among each data in a training data is not supported by the description and is not a common general technical knowledge at the time of filing. Therefore, the description requirement is not satisfied.

### [Claim 1]

A sugar content estimation system comprising:

a storage means for storing face images of people and sugar contents of vegetables produced by the people;

a model generation means for generating a determination model through machine learning, to which a face image of a person is input and from which a sugar content of a vegetable produced by the person is output, using training data containing the face images of the people stored in the storage means and the sugar contents of the vegetables,

a reception means for receiving an input of an face image; and

a processing means for outputting, using the generated determination model that has been generated by the model generation means, a sugar content of a vegetable produced by a person that is estimated based on the face image of the person inputted to the reception means.

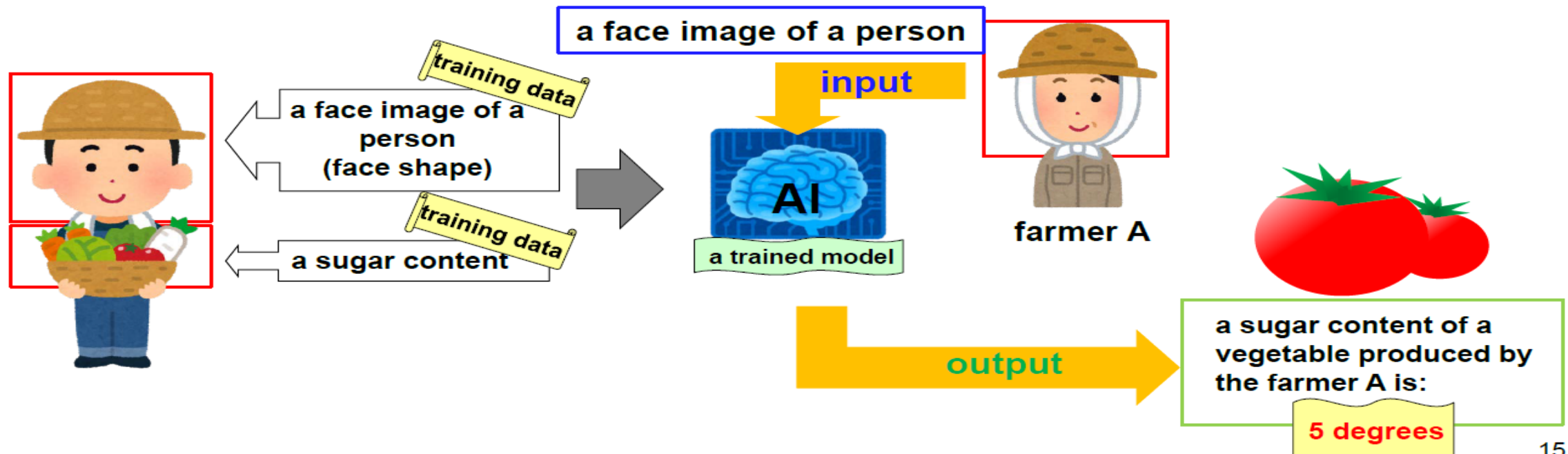

### [Overview of the Description]

It is an object of the present invention to provide a system that estimates a sugar content of a vegetable produced by a person based on his/her face image, taking advantage of the existence of a certain correlation between a face feature of a person and a sugar content of a vegetable produced by the person. For example, a face figure is characterized by a head length, face width, nose width, and lip width as shown in the figure. Here, a “sugar content” of a vegetable means a sugar content at the time when a certain period predetermined for each type of vegetables has passed after seeding. With this system, it is possible to estimate which person can produce a vegetable with a highest sugar content in a community.

A sugar content estimation system of the present invention firstly receives an input of a face image of a person by a user. A sugar content of a vegetable produced by a person is obtained using a determination model, to which a face image of the person is input and from which a sugar content of the vegetable produced by the person is output. The determination model is generated through a supervised machine learning using a known machine learning algorithm such as a convolutional neural network (CNN) by learning correlation between a face image of a person and a sugar content of a vegetable produced by the person.

### [Overview of Reason for Refusal]

#### •Article 36(4)(i) (Enablement Requirement)

According to the description, a human face image is used for an input to a determination model that estimates a sugar content of a vegetable produced by the person. The description says that a face feature is characterized by a head length, face width, nose width, and lip width, for example.

However, the description only discloses that there is a certain correlation between a face image of a person and a sugar content of a vegetable produced by the person and does not disclose any correlation or the like between them, though disclosing that a face feature is characterized by a head length, face width, nose width, and lip width, for example. It cannot be presumed that there is a correlation or the like between them, even if a common general technical knowledge at the time of filing is taken into consideration. Further, there is no performance evaluation result of an actually generated determination model shown in the description.

Accordingly, it is not possible for a person skilled in the art to derive a sugar content estimation system that outputs an estimation of a sugar content of a vegetable produced by a person based on an input of a face image of the person, even if the disclosure in the description and a common general technical knowledge at the time of filing are taken into consideration.

# Description Requirement: Case Example 51

ANAEROBIC ADHESIVE COMPOSITION

## Claim 1: violation of the support/enablement requirements

An invention of product is claimed. However, the invention is not evaluated using an actually-produced product and an estimation accuracy of a trained model is not verified. Further, it is not assumed that it is a common general technical knowledge at the time of filing that an estimation result by a trained model can be a substitution for an actual experimental result. Therefore, the description requirement is not satisfied.

### [Claim 1]

An anaerobic adhesive composition comprising: a 0.08 - 3.2 mass % compound A, a 0.001 – 1 mass % compound B, and a residue containing an anaerobically curable (meth)acrylate monomer, wherein the anaerobic adhesive composition shows the curing strength equal to or exceeding 30 % of the curing strength after 24 hours have passed, within 5 minutes from the start of curing.

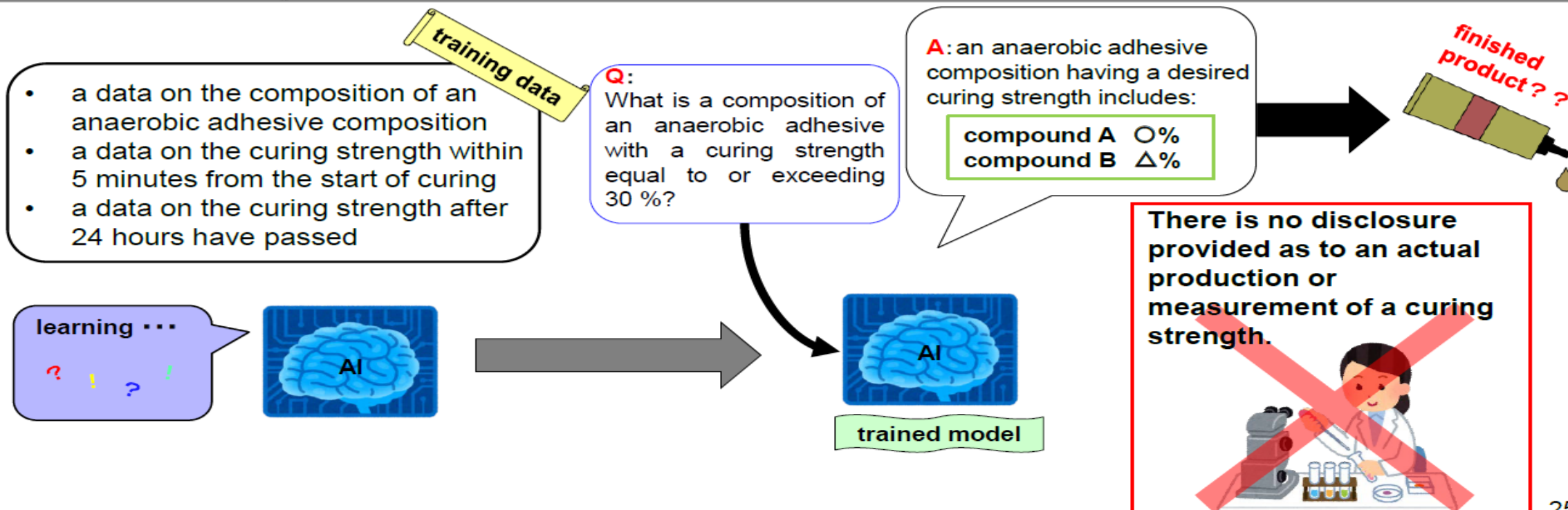

### [Overview of the Description]

In an embodiment, in order to derive an anaerobic adhesive composition attaining such an object, a conventionally known component data of an anaerobic adhesive composition, a curing strength data within 5 minutes from the start of curing, and a curing strength data after 24 hours have passed were input to a neural network; and then a trained model was prepared in a manner that a component of the anaerobic adhesive composition and a ratio between the curing strength within 5 minutes from the start of curing and the curing strength after 24 hours have passed were associated with each other. Further, an estimation result is disclosed showing the possibility where an anaerobic adhesive composition containing an anaerobically curable (meth)acrylate monomer can be obtained using the trained model, which realizes the curing strength equal to or exceeding 30% of the curing strength after 24 hours have passed within 5 minutes from the start of curing, by adding a 0.08 - 3.2 mass % compound A and a 0.001 - 1 mass % compound B in combination.

**(Notes)** The description does not disclose any embodiment in which an anaerobic adhesive composition is actually produced within the above combination ratio and then the curing strength is measured. Further, there is no verification shown on the estimation accuracy of the trained model. Furthermore, it is not known that the curing strength is enhanced within 5 minutes after the start of curing, by adding any one of a compound A, a compound B, and the combination thereof. Meanwhile, a measurement method and condition are specifically disclosed to measure the curing strength within 5 minutes after the start of curing and the curing strength after 24 hours have passed.

### [Overview of Reason for Refusal]

#### -Article 36(4)(i) (enablement requirement) / Article 36(6)(i) (support requirement)

It is the common technical knowledge at the time of filing that it is difficult to control an anaerobic adhesive composition so as to rapidly raise the curing temperature within 5 minutes or so after the start of curing, and that various conditions for production such as a type, combination, or combination ratio of polymer material, free radical initiator, or free radical reducing agent closely interact with each other.

The description only discloses that a trained model predicted that, as long as a composition meets the combination ratio prescribed in Claim 1, the composition has the curing strength equal to or exceeding 30% of the curing strength after 24 hours have passed, within 5 minutes from the start of curing. Further, the accuracy of an estimation value by the trained model is not verified, and there was no such a common technical knowledge at the time of filing that an estimation result by a trained model can be a substitution for an actual experimental result.

Any embodiment is not disclosed supporting the fact that the claimed composition shows the curing strength equal to or exceeding 30 % of the curing strength after 24 hours have passed within 5 minutes from the start of curing, by actually producing a composition including a 0.08 - 3.2 mass % compound A, a 0.001 - 1 mass % compound B, and a residue containing an anaerobically curable (meth)acrylate monomer, and then measuring the curing strength.

Thus, it does not seem that the description provide a sufficient disclosure of the invention in a manner that a person skilled in the art can produce the anaerobic adhesive composition as in Claim 1 that shows the curing strength equal to or exceeding 30 % of the curing strength after 24 hours have passed, within 5 minutes from the start of curing.

Claim 1 discloses an invention of an anaerobic adhesive composition comprising a 0.08 - 3.2 mass % compound A, a 0.001 - 1 mass % compound B, and a residue containing an anaerobically curable (meth)acrylate monomer, in which the curing strength of the composition is equal to or exceeds 30% of the curing strength after 24 hours have passed, within 5 minutes from the start of curing. Meanwhile, in view of the disclosure in the description and the common general technical knowledge at the time of filing, the description does not provide a sufficient disclosure so as to enable a person skilled in the art to recognize that an object of the present invention to provide an anaerobic adhesive composition showing the curing strength equal to or exceeding 30 % of the curing strength after 24 hours have passed within 5 minutes from the start of curing can be attained.

# Description Requirements in Summary

---

- **Correlation** among various training data
  - Needs to be verified in the description either by
    - ✓ Actual experimentation or
    - ✓ A common general technical knowledge



**AI's estimation** alone may **not** be **sufficient**

(Low credibility)

# Inventive Step (Non-obviousness)

---

Japanese Patent Act, Article 29 (2)

Where, prior to the filing of the patent application, **a person ordinarily skilled in the art of the invention** would have been able to **easily make** the invention based on an invention prescribed in any of the items of the preceding paragraph, **a patent shall not be granted** for such an invention notwithstanding the preceding paragraph.

→ Protect inventions which would not be disclosed but for the inducement of a patent (**inducement theory**).

# Inventive Step: Case Example 33

## CANCER LEVEL CALCULATION APPARATUS

**Claim 1: Mere a systemization of manually-operated tasks using AI and considered to be lack of inventive step.**

**[Claim 1]** A cancer level calculation apparatus that calculates a possibility that a subject person has cancer, using a blood sample of the subject person comprising  
a cancer level calculation unit that calculates a possibility that a subject person has cancer, in response to an input of measured values of A marker and B marker that have been obtained through blood analysis of the subject person,  
the cancer level calculation unit including a neural network that has been trained through machine learning using training data to calculate an estimated cancer level in response to the input of the measured values of A marker and B marker.

### [Cited Invention 1]

A cancer level calculation method of calculating a possibility that a subject person has cancer carried out by a doctor, using a blood sample of the subject person comprising  
a step of cancer level calculation, wherein a possibility that a subject person has cancer is calculated, using measured values of A marker and B marker that have been obtained through blood analysis of the subject person.

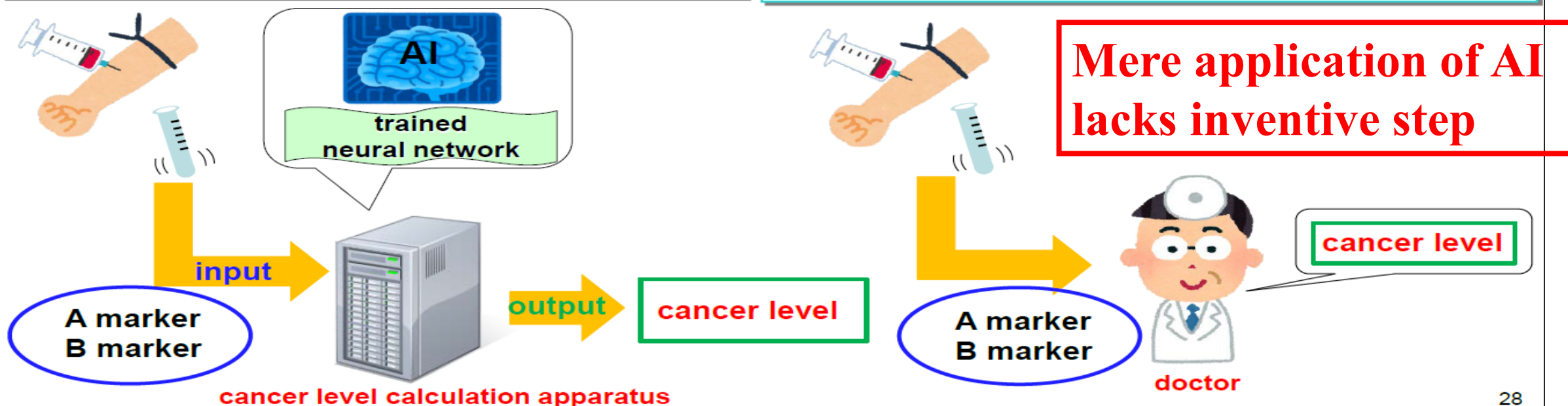

### [Well-known Art]

It is well-known, in the field of machine learning, to calculate an output data representing a possibility that a subject person has a certain disease based on a prescribed set of input data on the subject person, using a trained neural network, which has been trained through machine learning with training data. The training data contains an input data that has been collected from multiple people, each of which consists of a prescribed set of input data (biological data etc.) on each person, and an output data representing a possibility that the person has the disease.

### ✗ Claim 1 lacks inventive step.

#### [Overview of Reason for Refusal]

The invention of Claim 1 and Cited Invention 1 are different from each other at the point below.

#### (Difference)

The invention of Claim 1 is a cancer level calculation apparatus that calculates a possibility that a subject person has cancer in response to an input of measured values of A marker and B marker, using a trained neural network through machine learning with training data. Meanwhile, Cited Invention 1 discloses a cancer level calculation method through which a doctor calculates a possibility that a subject person has cancer based on measured values of A marker and B marker.

The difference is assessed as follows.

.....

Both Cited Invention 1 and the well-known art relate to estimation of the possibility of illness, and they share a common problem to be solved. It is mere the exercise of the ordinary creativity of a person skilled in the art to systemize an estimation method carried out by a doctor in the medical field using a computer or the like.

In view of the factors above, a person skilled in the art can easily conceive of systemizing a calculation method of a possibility that a subject person has cancer, which has been carried out by a doctor, by applying the well-known art to Cited Invention 1, and calculating a possibility that a subject person has cancer in response to an input of measured values of A marker and B marker using a trained neural network through machine learning with training data.

Further, a person skilled in the art can readily anticipate the effects of the invention of Claim 1. Also, there are no obstructive factors found to apply the well-known art to Cited Invention 1.

# Inventive Step: Case Example 34

## ESTIMATION SYSTEM OF HYDROELECTRIC GENERATING CAPACITY

Claim 1: mere a modification of estimation method to estimate output data based on input data, and considered to be lack of inventive step  
 Claim 2: a significant effect is found because of addition of training data for machine learning, and considered to have inventive step

**[Claim 1]** An estimation system of a hydroelectric power generating capacity of a dam comprising:  
 a neural network that is built by means of an information processor, the neural network having an input layer and an output layer, in which an input data to the input layer containing a precipitation amount of the upper stream of a river, a water flow rate of the upper stream of the river, and a water inflow rate into a dam during a predetermined period between a reference time and a predetermined time before the reference time, and an output data from the output layer containing a hydroelectric power generating capacity in the future after the reference time;  
 a machine learning unit that trains the neural network using a training data corresponding to actual values of the input data and the output data;  
 and  
 an estimation unit that inputs the input data to the neural network that has been trained by the machine learning unit with setting a current time as the reference time, and then calculates an estimated value of a future hydroelectric power generating capacity based on the output data of which reference time is the current time.

**[Claim 2]** The estimation system of a hydroelectric power generating capacity as in Claim 1, wherein the input data to the input layer further contains a temperature of the upper stream of the river during the predetermined period between the reference time and the predetermined time before the reference time.

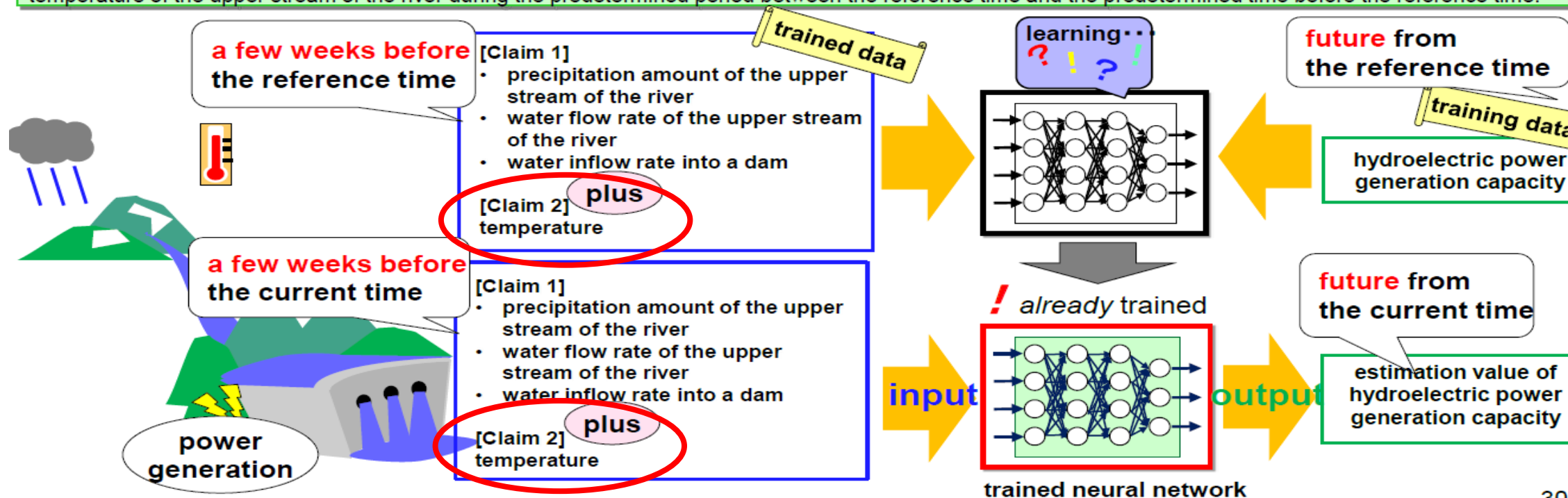

# Inventive Step: Case Example 34

## ESTIMATION SYSTEM OF HYDROELECTRIC GENERATING CAPACITY

**[Well-known Art]** In the technical field of machine learning, it is well-known that an estimation process of an output in the future is carried out based on an input of time series data in the past, by using a trained neural network which has been trained with a training data containing an input of time series data in the past and a certain output in the future.

**✗ The invention of Claim 1 lacks an inventive step.**

**○ The invention of Claim 2 has an inventive step.**

### [Overview of Reason for Refusal]

The invention of Claim 1 and Cited Invention 1 are different from each other at the point below.

#### (Difference)

The invention of Claim 1 realizes an estimation of a hydroelectric power generating capacity by means of a neural network having an input layer and output layer. Meanwhile, Cited Invention 1 realizes an estimation of a hydroelectric power generating capacity by means of a regression equation model.

The difference is assessed as follows. . . . . Cited Invention 1 and the well-known art are common with each other in estimating a certain output in the future based on an input of time series data in the past, with reference to a correlation among data. Therefore, a person skilled in the art could easily derive a configuration that enables estimation of a hydroelectric power generating capacity, by applying the well-known art to Cited Invention 1 and adopting a trained neural network in substitution of a regression equation model.

#### (Basis for Determination that there is No Reason for Refusal found)

The invention of Claim 2 and Cited Invention 1 are different from each other at the point below.

#### (Difference)

The invention of Claim 2 contains, in an input data into an input layer, a temperature of the upstream of the river during a predetermined period between a reference time and a predetermined time before the reference time. Meanwhile, Cited Invention 1 does not have such a configuration.

The difference is assessed as follows.

The invention of Claim 2 uses a temperature of the upstream of the river for estimation of a hydroelectric power generating capacity. There is no prior art found disclosing such use of a temperature of the upstream of the river. Accordingly, it is not a common general technical knowledge that there is a correlation between a temperature and a hydroelectric power generating capacity.

Generally, an input of data of which correlation is unknown may cause a noise in machine learning. However, the invention of Claim 2 uses an input data containing a temperature of the upstream of the river during a predetermined period between a reference time and a predetermined time before the reference time. This enables a highly accurate estimation of a hydroelectric power generating capacity, taking an increase of inflow rate due to meltwater in the spring into consideration. It is a significant effect that a person skilled in the art cannot expect.

Accordingly, it does not considered to be a mere workshop modification that can be carried out in application of the well-known art to Cited Invention 1 by a person skilled in the art to contain, in an input data in an estimation of a hydroelectric power generating capacity, a temperature of the upstream of the river during a predetermined period between a reference time and a predetermined time before the reference time.

# Inventive Step in Summary

---

- **Correlation not presumed** by a common general technical knowledge
  - ✓ May **satisfy inventive step**
  - ✓ May **deny description requirements**, unless actual experimentation verifies AI's estimation



**Correlation** among training data may work in the **opposite** directions

# Inventive Step in Summary

---

- **Mere application of AI = exercise of the ordinary creativity by PHOSITA**

- ✓ May **deny** inventive step

- ✓ **Same practice as in computer-implemented inventions**

Mere systemization of manually-operated tasks by computers may lack incentive step



**PHOSITA is expected to use AI to the same extent as general purpose computers.**

# Broader Implications?

---

- 2 kinds of AI-related inventions in JPO's Handbook
  - a. Inventions applying AI technologies in various fields
  - b. Inventions of products whose **functions is presumed by AI**  
e.g. Case example 51 anerobic adhesive composition
- In both types, applicants **admit** the use of AI in either claims or description
- Applicants may **not disclose** the use of AI for the second type inventions
  - ✓ AI is **not** an element of the claims

# Broader Implications?

---

- ✓ **No** incentives to disclose AI's estimation

They have to disclose either actual experimentation or a common general technical knowledge in order to satisfy disclosure requirements

- ✓ **Hardly know** the use of AI by applicants in their R&D process



- Many AI-related inventions created with the use of AI **without** disclosing it?
- Should **all applications, whether or not they disclose** the use of AI, be examined on the assumption that **PHOSITA would use AI**?

# Justifying PHOSITA with AI?

---

- Justifiable under inducement theory

**No** patent incentives are necessary for an invention that **PHOSITA** would easily create by using AI

- Consistent with the notion of PHOSITA in practice

➤ Examination Guidelines, Part III Chapter 2 Section 2 2.

One of the conditions of PHOSITA is “A person who is able to use **ordinary technical means** for research and development (including document analysis, experiment, technical analysis, manufacture, etc)

# Pyrimidine Derivative Case

---

- IP High Court, April 13, 2018, 2016 (Gyo-Ke) 10182, 10184
  - The Invention : a compound in pharmaceuticals

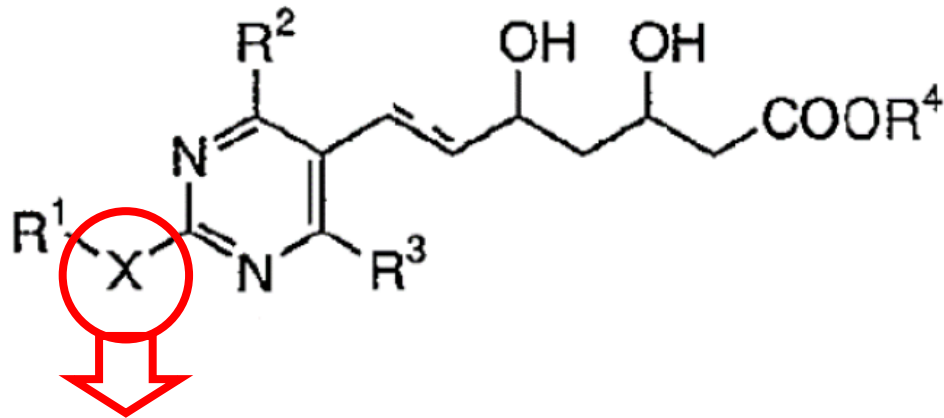

- Difference between the Invention and the main cited invention
- Described as **one** of more than **20 million alternatives** of the general formula in the sub-cited invention (Markush claims)

➡ *Does the combination of these inventions deny the inventive step?*

# Pyrimidine Derivative Case

---

## ➤ IP High Court held

- If a compound was described in the form of **general formula in the prior art** and the general formula had an **enormous** number of alternatives, it was **impossible to extract** a specific technical idea embodied in a specific alternative and **find it as a cited invention**, unless there was a circumstance where the specific alternative should be positively or preferentially selected.
- In this case, since **no** circumstances could be found where the specific alternative out of more than 20 million alternatives should be selected, **inventive step** may **not be denied**

# AI's impacts on the holdings

---

- The development and diffusion of AI may affect the court's holding in future
  - More than 20 million alternatives may be **enormous** for **humans** today but may **not be so** for **AI** in future

e.g. Materials informatics



- ✓ *AI may make it **easier** for **PHOSITA** to find a solution that they would hardly do by conventional technologies, which may **raise the threshold of inventive step***
- ✓ *However, is it fair to say that AI may be “**ordinary technical means**” that PHOSITA would use ?*

# Is the use of AI widespread?

## Introduction of AI in Process

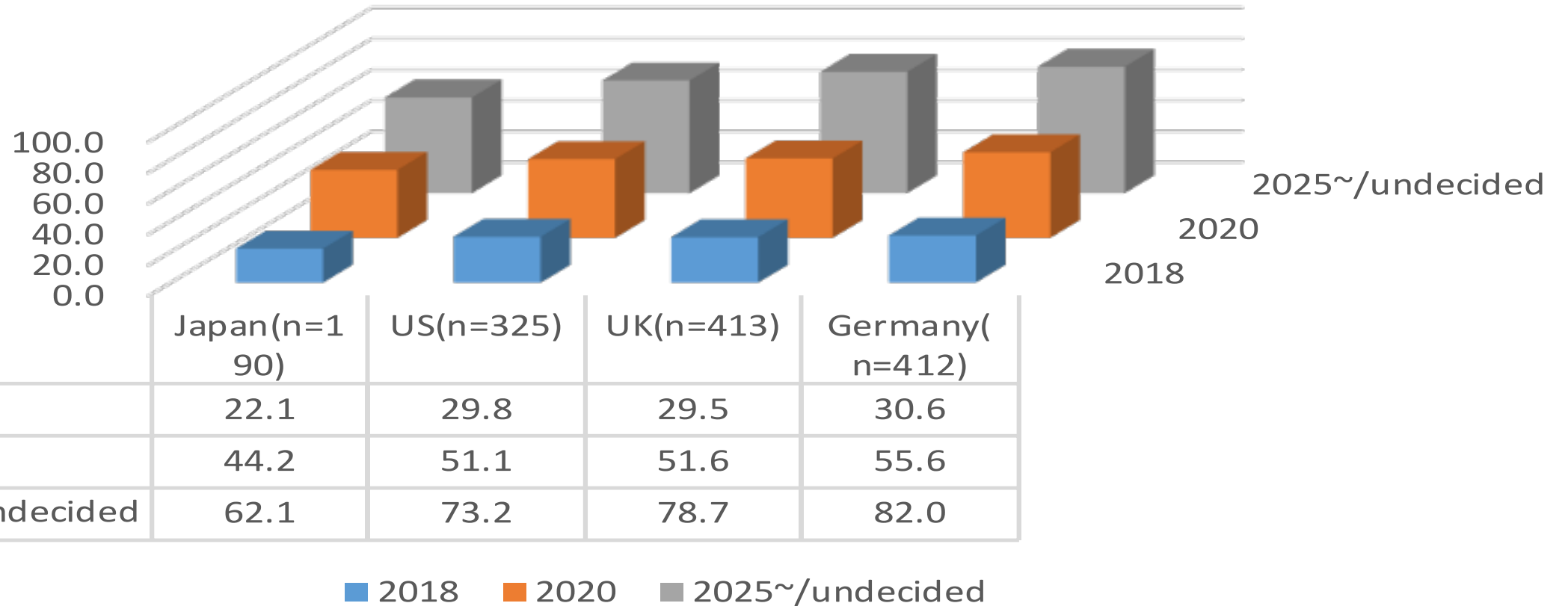

# Is the use of AI widespread?

## Introduction of AI in Product

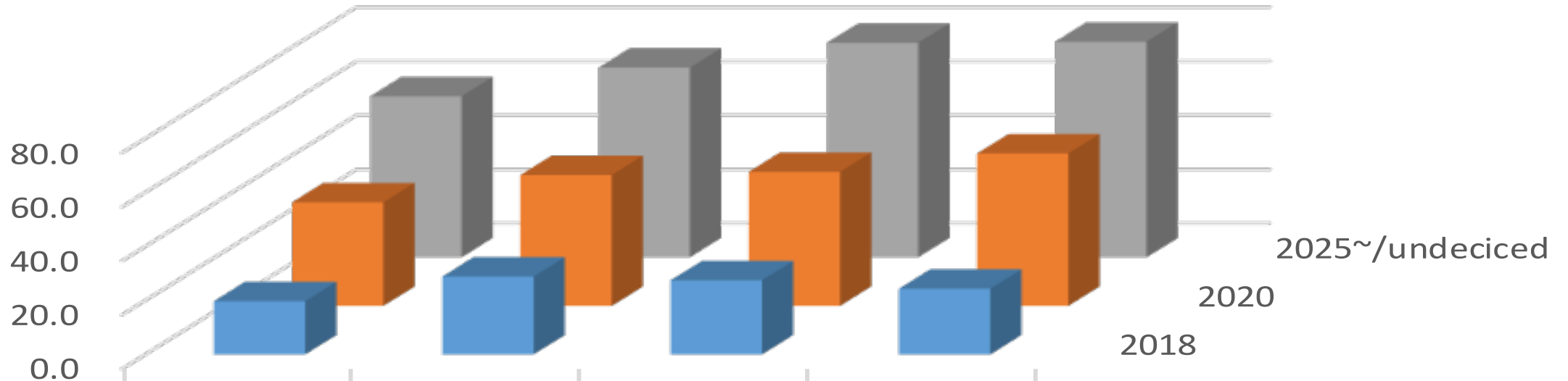

	Japan(n=188)	US(n=312)	UK(n=413)	Germany(n=411)
2018	19.7	28.8	27.4	24.3
2020	38.3	48.4	49.6	56.4
2025~/undecided	59.6	70.2	79.4	79.8

Source: created by author based on the Ministry of Internal Affairs and Communications, “Information and Communications in Japan White Paper 2018” (2018)

# PHOSITA with AI

---

- Although AI has not been widely used at this moment of time, it is forecasted to be widespread rapidly
  - Incentives in the market for introducing AI (outside the patent law)
    - ✓ To supplement the shortage of labor force
    - ✓ To make the business more efficient



It may be **reasonable** to expect PHOSITA to use AI, regardless of whether applicants used it or not

Not applicants but **PHOSITA** determines the level of inventive step

# JPO's unconscious support

---

- JPO's Handbook

- Mere application of AI = exercise of the ordinary creativity by PHOSITA

PHOSITA is presumed to use **AI** to the **same extent** as **general purpose computers**.



If PHOSITA could use **general purpose computers** as **ordinary technical means**, they could also use **AI** as **ordinary technical means**.

# How is PHOSITA with AI taken into account in practice?

---

## ➤ Proposals to test **reproducibility** by AI

Ryan Abbott, *Everything is obvious*, 66 UCLA L. REV. 39 (2018)

**1<sup>st</sup> step** Determine the extent to which AI is used in the field



**2<sup>nd</sup> step** Identify specific AIs



e.g. Deep Mind (Google) and Watson (IBM)

**3<sup>rd</sup> step** Test reproducibility

by investigating **whether specified AI would reproduce the invention within reasonable time**

# How is PHOSHITA with AI taken into account in practice?

---

- The 1<sup>st</sup> step is unnecessary due to the above-mentioned reason
- Practical difficulties
  - Inventive steps should be examined at the **filing (priority) date**
    - ✓ Need to **downgrade** AI's capabilities improved after the filing date
    - ✓ Training **data** should be **restricted** to date existed at the filing date

*It may **not** be **feasible** to reproduce such an AI.*

 *In **other fields** of technologies, patent examiners are **not** expected to conduct an experimentation in determining the inventive step.*

*Why do they have to verify reproducibility of AI-related inventions?*

# How is PHOSITA with AI taken into account in practice?

---

➤ PHOSITA = legal fiction ≠ real person

- Inquiry in inventive step

- ✓ does **not** aim at **scientific verification**

- ✓ **normative, legal** question in light of purposes of patent law



Testing reproducibility by AI may **not** be necessary

Then, what alternatives?

Experts' opinion (likely to be submitted at later stages such as the lawsuits, invalidation trials, post-grant oppositions, etc.) ?

# Conclusion

---

➤ JPO's updated Handbook

- Took one step forward in the right direction
- **Not enough**, in particular, for **inventive step**



- ✓ The notion of **PHOSITA with AI** may have **broader** impacts such as **raising the threshold of inventive step**
- ✓ There remain many questions...

# Conclusion

---

- If the development of AI continues to raise the threshold of inventive step as Prof. Abbott said “everything is obvious,” do we have to worry that no human inventors could obtain patents, thereby discouraging them?

NO.

- Endless generation of AI output ➡ No market failure (underproduction)
- Investments are still necessary, but
  - ✓ Inventions of AI technologies could be patentable
  - ✓ Other appropriation mechanism to recoup investment  
e.g. leadtime, secrecy, complementary assets (sales network, factories)

# Other Patent Offices' reports

---

- USPTO “Public Views on Artificial Intelligence and Intellectual Property” (October 2020)

“Many commenters asserted that AI has the potential to affect the level of ordinary skill in an art.”

- UKIPO “Government response to call for views on artificial intelligence and intellectual property” (23 March 2021)

A large majority of responses’ “view was that “the person skilled in the art” has a range of tools available to them and AI technologies will be one of those tools.”